

SC5-5.5

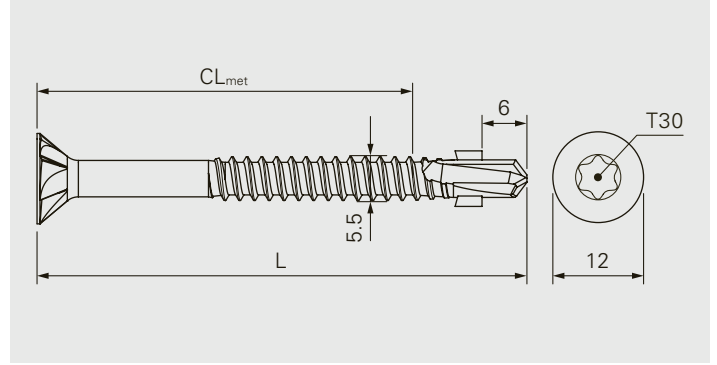

Description

Self-drilling fastener made of carbon steel with cutting wings and countersunk head

Application

Fastening of timber boards onto supporting steel structures

Component 1 (t_i)

Timber OSB3	>=12.0
Timber P2	>=16.0
Timber P4	>=38.0
Timber P6	>=38.0

Component 2 (t_{ii})

Steel	1.75–5.0
-------	----------

Please refer to AbZ: Z-14.4-872

Fastener material

Carbon steel, hardened, Durocoat® 480

Features and Benefits

- Fastener head with milling grooves for flush-mounted installation without damaging the timber surface
- Cutting wings for efficient drilling of the through hole in timber
- Suitable for installation with CF250 and CF250 PL setting tools

Approvals



All measures in mm

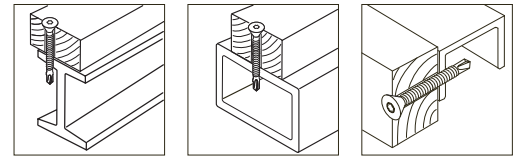

Fastener in carbon steel onto steel

Product code	PU	L	CL _{met}	
SC5/46-12CC-5,5x60	1000	60	25-46	1580102

Please refer to the "Definition of clamping range and fixing thickness" in the technical introduction for definitions and diagrams related to CL_{met}.

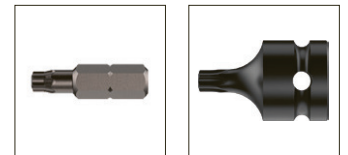

Accessories

Product description	PU	Insert drive	Recess	L	
Bit T30-25-HEX 1/4"	10	HEX 1/4"	T30	25	1690315
Bit T30-35-1/2"	1	SQ 1/2"		35	1690314

Tools

Product description	PU	Insert drive	Voltage V	rpm	
CF250-230V-1560 RPM-COMPL	1	1/4"	220	1560	9653444
CF250-PL-230V-COMPL					1104016

All measures in mm

All information is non-binding and without guarantee. Before using the products, all specifications and calculations must be checked by a suitably qualified person and local regulations must be observed. This document is subject to revision. We reserve the right to make technical changes.