

SX2-D7-4.8-A2

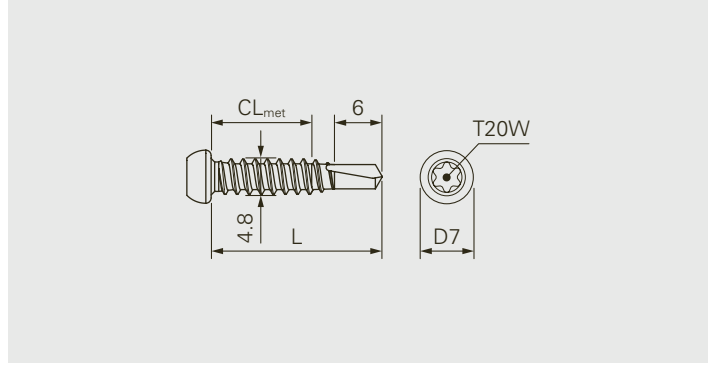

Description

Self-drilling fastener made of stainless steel with small head shape

Application

Fastening of flashings onto sandwich panels
Fastening of flashings onto profile sheets

Component 1 (t_i)

Steel	0.4–1.5
Steel	2×0.4–0.88
Aluminium	0.5–1.5

Component 2 (t_{ii})

Steel	0.4–1.5
Steel	2×0.4–0.88
Aluminium	0.5–1.5

Fastener material

Austenitic stainless steel A2, hardened tip

Features and Benefits

- Aesthetic small head shape in rivet look

Approvals



All measures in mm

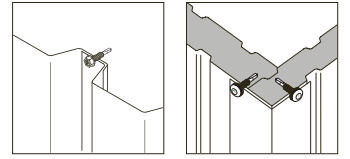

Fastener in A2

Product code	PU	L	CL _{met}	
SX2-D7-4,8x22-A2	500	22	0-9	1747715
SX2-D7-4,8x22-A2	100			1747691

Please refer to the "Definition of clamping range and fixing thickness" in the technical introduction for definitions and diagrams related to CL_{met}.

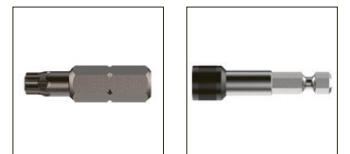

Accessories

Product description	PU	Insert drive	Recess	L	
Bit T20W-25-HEX $\frac{1}{4}$ "	1	HEX $\frac{1}{4}$ "	T20W	25	895280
Bit holder ZA $\frac{1}{4}$ "-58			HEX $\frac{1}{4}$ "	58	1162306

All measures in mm

All information is non-binding and without guarantee. Before using the products, all specifications and calculations must be checked by a suitably qualified person and local regulations must be observed. This document is subject to revision. We reserve the right to make technical changes.