

SD3-5.5

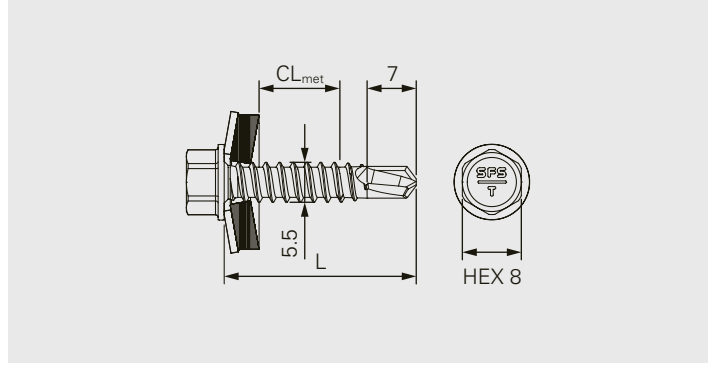

Description

Self-drilling fastener made of carbon steel with sealing washer

Application

Fastening of profile sheets onto metal profiles
Fastening of profile sheets onto liner trays

Component 1 (t_I)

Steel 0.5–1.5

Component 2 (t_{II})

Steel 1.25–3.0
Steel 2×0.75–1.5

Fastener material

Carbon steel, hardened, Durocoat® 480
Sealing washer: Carbon steel galvanized, EPDM-seal

Features and Benefits

- High corrosion durability by special galvanic coating
- High quality EPDM-seal with long durability

Approvals



All measures in mm

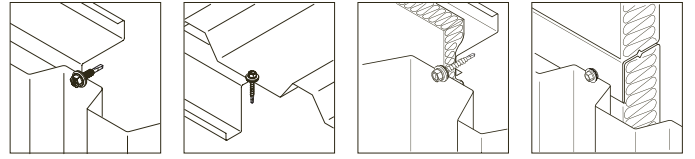

Fastener in carbon steel

Product code	PU	L	CL _{met}	T16
SD3-T16-5,5×25	500	25	0–11	1506612
SD3-T16-5,5×45		45	0–31	1506617

Please refer to the "Definition of clamping range and fixing thickness" in the technical introduction for definitions and diagrams related to CL_{met}.

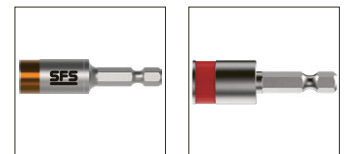

Accessories

Product description	PU	Insert drive	Recess	L	
SOK-IT-¼"-57-8Nm	1	HEX¼"	HEX8	57	1667322
Socket E308-¼"-50				50	1646160

All measures in mm

All information is non-binding and without guarantee. Before using the products, all specifications and calculations must be checked by a suitably qualified person and local regulations must be observed. This document is subject to revision. We reserve the right to make technical changes.