

SDP3-D10-TC19-5.5

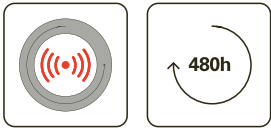
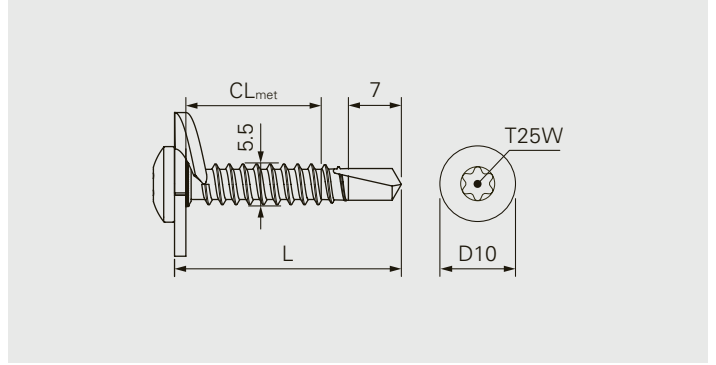

Description

Self-drilling fastener made of carbon steel with self-coring cutting disc

Application

Fastening of single-ply panels onto metal profiles
Fastening of overlaps of single-ply panels

Component 1 (t_i)

Steel¹⁾ 0.5–1.0

Component 2 (t_{ii})

Steel¹⁾ 0.5–1.0
Steel 1.0–3.0

¹⁾ Inner cover sheet

Fastener material

Carbon steel, hardened, Durocoat® 480
Cutting disc: Carbon steel galvanized

Features and Benefits

- Fast and smooth penetration of membrane and insulation by self-coring cutting disc
- Small core hole with minimal disturbance of the insulation
- High corrosion durability by special galvanic coating

Approvals



All measures in mm

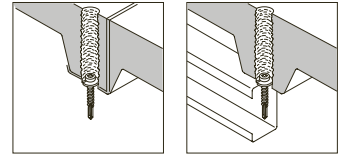

Fastener in carbon steel

Product code	PU	L	CL _{met}	
SDP3-D10-TC19-5,5×30	500	30	0-16	1645611

Please refer to the "Definition of clamping range and fixing thickness" in the technical introduction for definitions and diagrams related to CL_{met}.



Accessories

Product description	PU	Insert drive	Recess	L	
Bit T25W-175-HEX¼"	5	HEX¼"	T25W	175	727979

All measures in mm

All information is non-binding and without guarantee. Before using the products, all specifications and calculations must be checked by a suitably qualified person and local regulations must be observed. This document is subject to revision. We reserve the right to make technical changes.