

SW3-H15-6.5

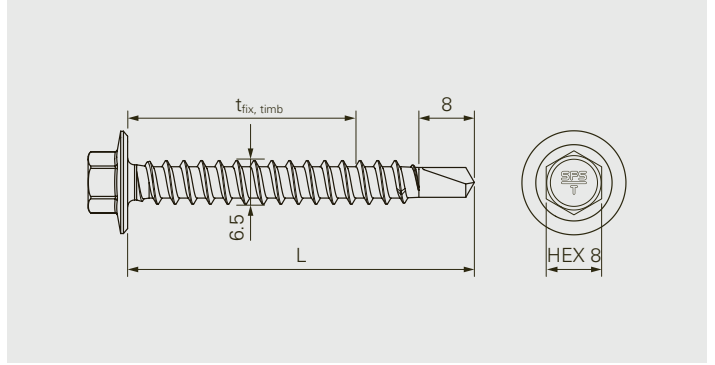
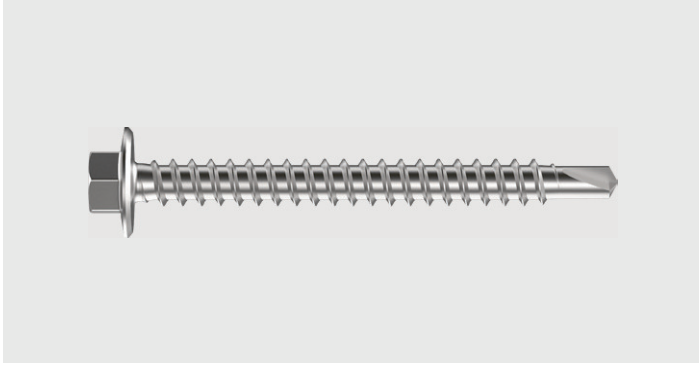

Description

Self-drilling fastener made of carbon steel with wide flange

Application

Fastening of metal decks onto timber
Fastening of liner trays onto timber

Component 1 (t_I)

Steel 0.63-1.5

Component 2 (t_{II})

Timber $l_{ef} \geq 35$

Fastener material

Carbon steel, hardened, Durocoat® 480

Features and Benefits

- Wide flange for high technical values in the application
- High corrosion durability by special galvanic coating

Approvals



All measures in mm

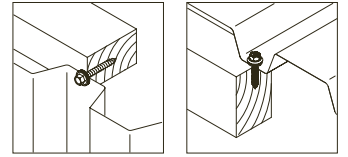

Fastener in carbon steel

Product code	PU	L	t _{fix, timb}	
SW3-H15-6.5x50	250	50	0-8	1069981
SW3-H15-6.5x65	250	65	0-23	1420323

Please refer to the "Definition of clamping range and fixing thickness" in the technical introduction for definitions and diagrams related to t_{fix, timb}.

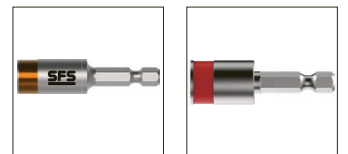

Accessories

Product description	PU	Insert drive	Recess	L	
SOK-IT-¼"-57-8Nm	1	HEX¼"	HEX8	57	1667322
Socket E308-¼"-50				50	1646160

All measures in mm

All information is non-binding and without guarantee. Before using the products, all specifications and calculations must be checked by a suitably qualified person and local regulations must be observed. This document is subject to revision. We reserve the right to make technical changes.