

# SD6-H15-E11-5.5

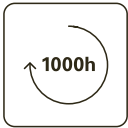
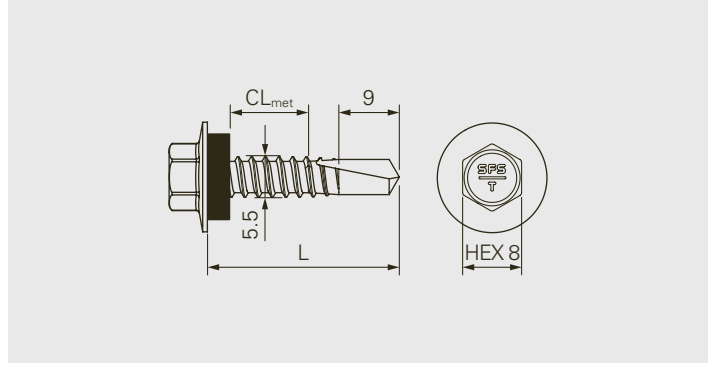

## Description

Self-drilling fastener made of carbon steel with wide flange and damping ring

## Application

Fastening of metal decks onto metal profiles  
Fastening of liner trays onto metal profiles

## Component 1 (t<sub>i</sub>)

Steel 0.63–1.5

## Component 2 (t<sub>ii</sub>)

Steel 1.5–5.0

## Fastener material

Carbon steel, hardened, Durocoat® 1000  
Damping ring: EPDM

## Features and Benefits

- Wide flange for high technical values in the application
- Elastic damping ring for low risk of overwinding, overtightening and fastener breakages
- Increased security against unwinding
- High corrosion durability by duplex coating

## Approvals



All measures in mm

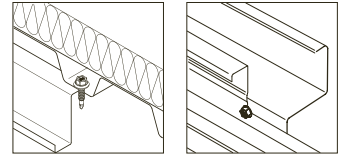

## Fastener in carbon steel

Product code	PU	L	CL <sub>met</sub>	
SD6-H15-E11-5,5x22	500	22	0-8	1769390

Please refer to the "Definition of clamping range and fixing thickness" in the technical introduction for definitions and diagrams related to CL<sub>met</sub>.

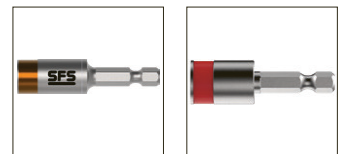

## Accessories

Product description	PU	Insert drive	Recess	L	
SOK-IT-¼"-57-8Nm	1	HEX¼"	HEX8	57	1667322
Socket E308-¼"-50				50	1646160

### All measures in mm

All information is non-binding and without guarantee. Before using the products, all specifications and calculations must be checked by a suitably qualified person and local regulations must be observed. This document is subject to revision. We reserve the right to make technical changes.